



**Putzmeister**



# The new iLS pump generation

intelligent **L**ow **S**troke – for more power and maximum service life

# Operations under high pressure – lasting, reliable, cost-saving

## The Putzmeister iLS pump generation is setting standards across the board

The heart of every truck-mounted concrete pump is the pump itself. Its mode of action, durability and operability are the economic indicators and determine the success of your operations.

This is precisely the basis of the iLS pump generation, which delivers significantly improved data across the board. The iLS pump generation is the logical advancement of the tried and proven HLS generation.

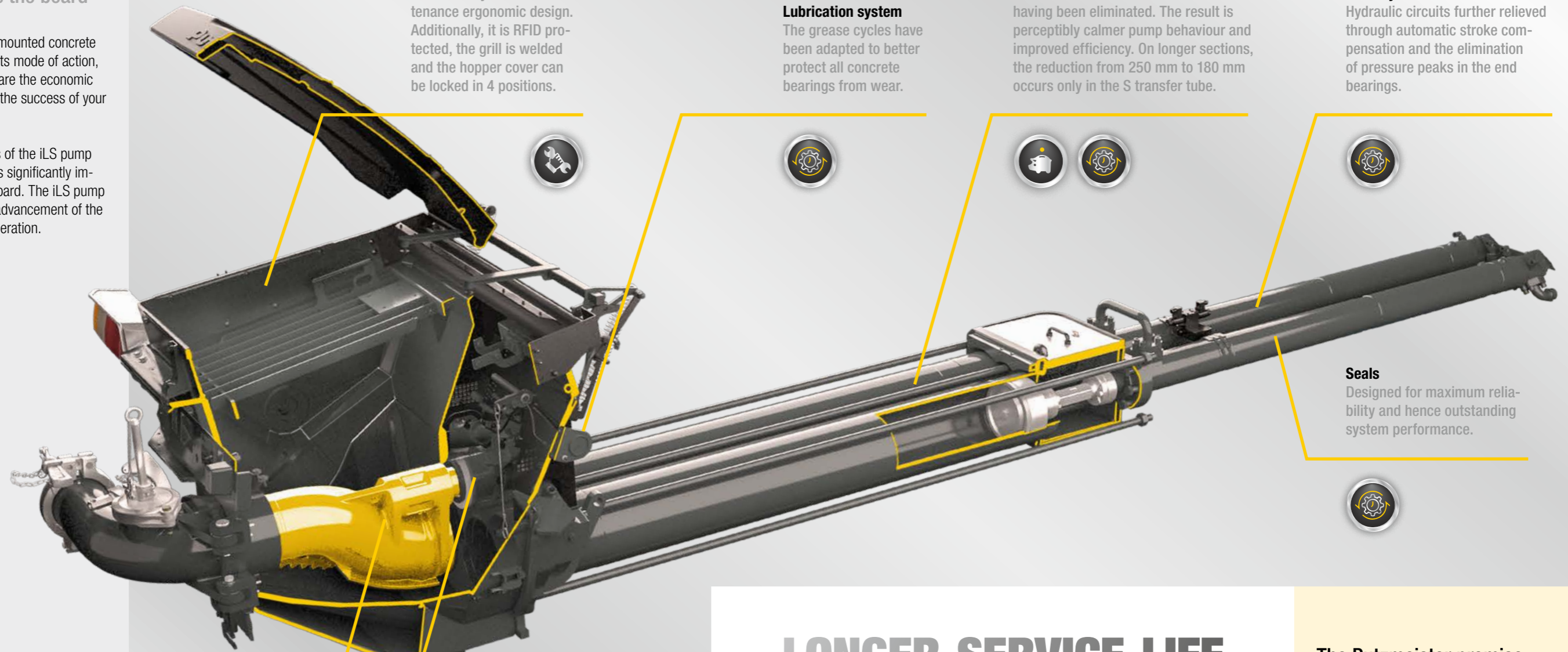

**Hopper**  
The hopper has a user-friendly and low-maintenance ergonomic design. Additionally, it is RFID protected, the grill is welded and the hopper cover can be locked in 4 positions.

**Lubrication system**  
The grease cycles have been adapted to better protect all concrete bearings from wear.



**Concrete cylinder**  
Consistent concrete flow due to the constriction before the S transfer tube having been eliminated. The result is perceptibly calmer pump behaviour and improved efficiency. On longer sections, the reduction from 250 mm to 180 mm occurs only in the S transfer tube.

**Drive cylinder**  
Hydraulic circuits further relieved through automatic stroke compensation and the elimination of pressure peaks in the end bearings.

**Seals**  
Designed for maximum reliability and hence outstanding system performance.

**S transfer tube**  
The process-optimised, hardened valve operates smoothly and guarantees extreme durability.

**S transfer tube swivel bearing**  
The hopper wall thickness and the bearing surface have been doubled for maximum reliability.

-  Durable and cost-saving
-  Easy to handle
-  Outstanding performance

**LONGER SERVICE LIFE**  
**LOW MAINTENANCE**  
**OPTIMISED EFFICIENCY**  
**OPTIMISED ACCESSIBILITY**  
**EASY CLEANING**  
**BEST PERFORMANCE!**

**The Putzmeister promise**

We promised to build you machines that increase your production and give you a competitive edge – and these machines are being continuously developed. Because innovative technologies and durable quality need to adapt to your ever-changing daily challenges. This is how our new generation of pumps has emerged. They stand for optimum output with low fuel consumption, wear and costs.

**Your Putzmeister Team**

# Each and every detail contributes to the whole

## Precisely matched for high economic efficiency

- 3%** Efficiency increase through the prevention of leaks
- 10%** Better suction behaviour thanks to the elimination of constrictions in the concrete flow
- Up to 25%** Less fuel consumption through the intelligent control and the use of EOC 2.0

To summarise, this realistically results in a saving of 10%. This value was determined in practice in co-operation with our dealers.

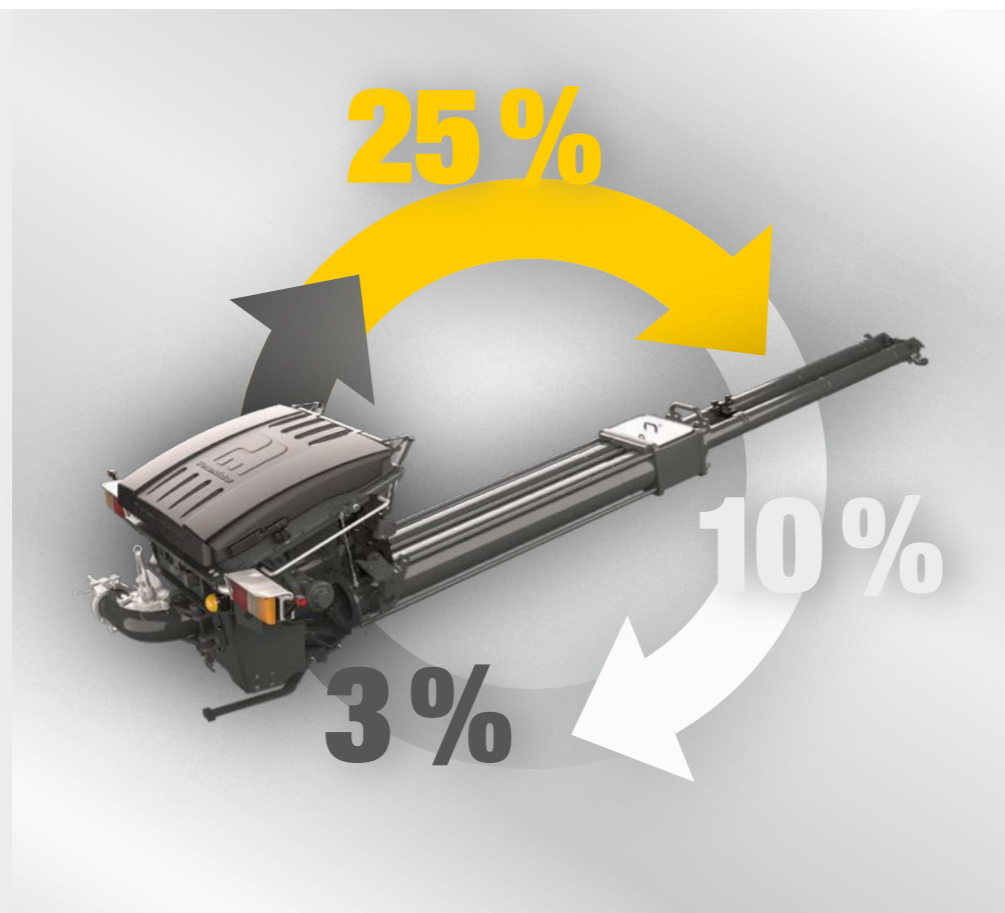

## Greater cylinder capacity = fewer strokes, less wear

This calculation is correct. A large cylinder and the resultant high cylinder capacity means that the pump requires fewer strokes to achieve a comparable flow rate.

The lower number of strokes automatically reduces wear, especially with highly abrasive concrete mixtures. The service life is longer, which in turn means you work at maximum efficiency. The cylinder fill level has also been significantly improved.

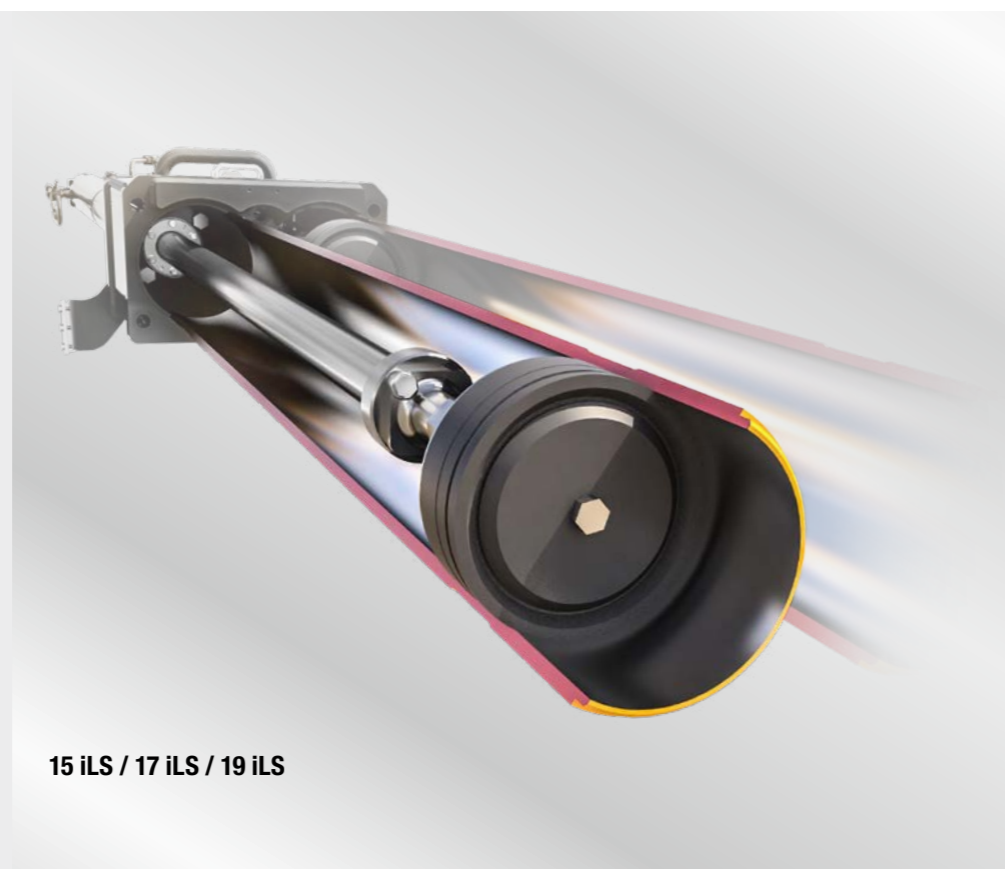

15 ILS / 17 ILS / 19 ILS



## Hopper

The convenient handling of the hopper cover with 4 spring-lock settings (Fig. A), easy access and maintenance (Fig. B), the optimised underside guard and the simplified bar change with split bolts (Fig. C) simply operations and improve user-friendliness. The dead points (Fig. D) throughout the hopper have also been consistently eliminated, significantly reducing deposits and saving time during the cleaning routine.

Further improvements concern the welded funnel grill and the simplified cleaning.

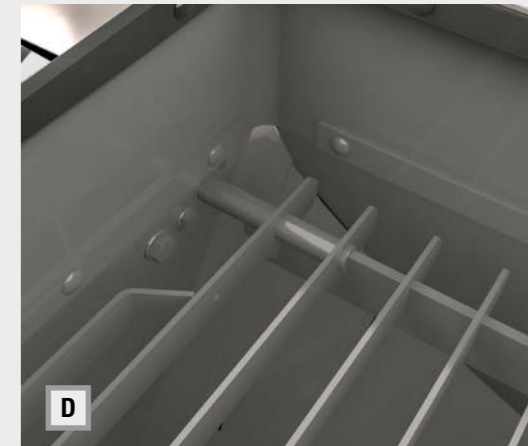
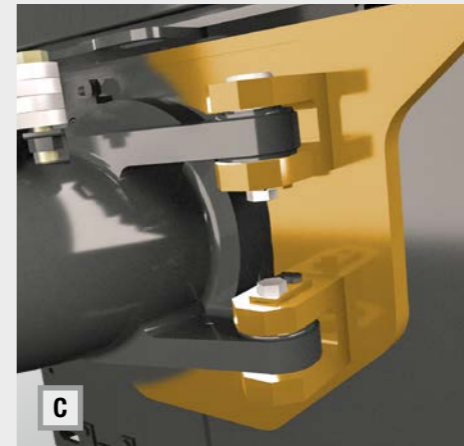
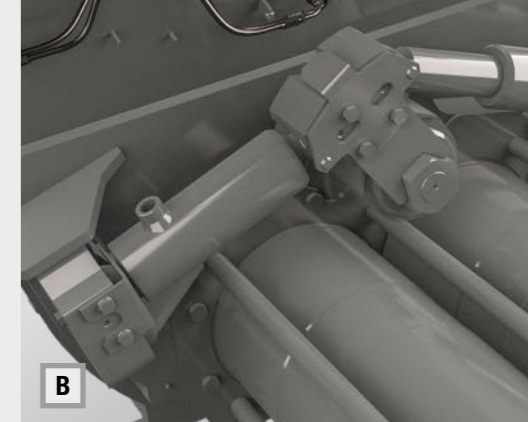

## Concrete cylinders

Physical phenomena cause higher forces at the end position of the cylinders and hence increased wear. The Putzmeister concrete cylinder can be turned and re-used – the positive consequence is a much longer service life.

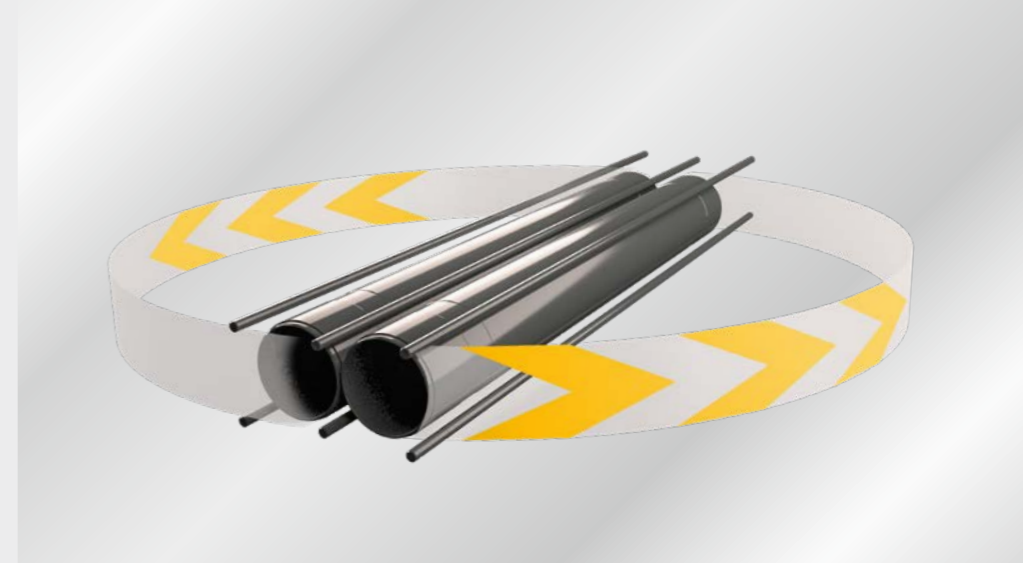

## S transfer tube pivot bearing

The re-dimensioning of the S-valve bearing construction has effectively reduced the bearing load by 50%. So the service life is enhanced. Together with new seals, the hardened bushes and the sturdy rotation lock, the maximum bearing reliability is therefore achieved.



## Seals

The highly robust seals of the hydraulic cylinder pistons play a key role in increasing system performance and prevent practically all oil leaks.



# The iLS pumps are setting new standards – high performance with reduced operating costs

## Transition to the S transfer tube

The transition from the cylinder to the S transfer tube is designed without a diameter reduction. This prevents the so-called “dead spaces” in which used concrete accumulates. As a result, maintenance costs are significantly reduced, service life is extended, the fill level is maximised and cleaning is simple and effective.

## S transfer tube

The uniform tapering of the S transfer tube optimises the flow behaviour and also contributes to the extremely long service life.

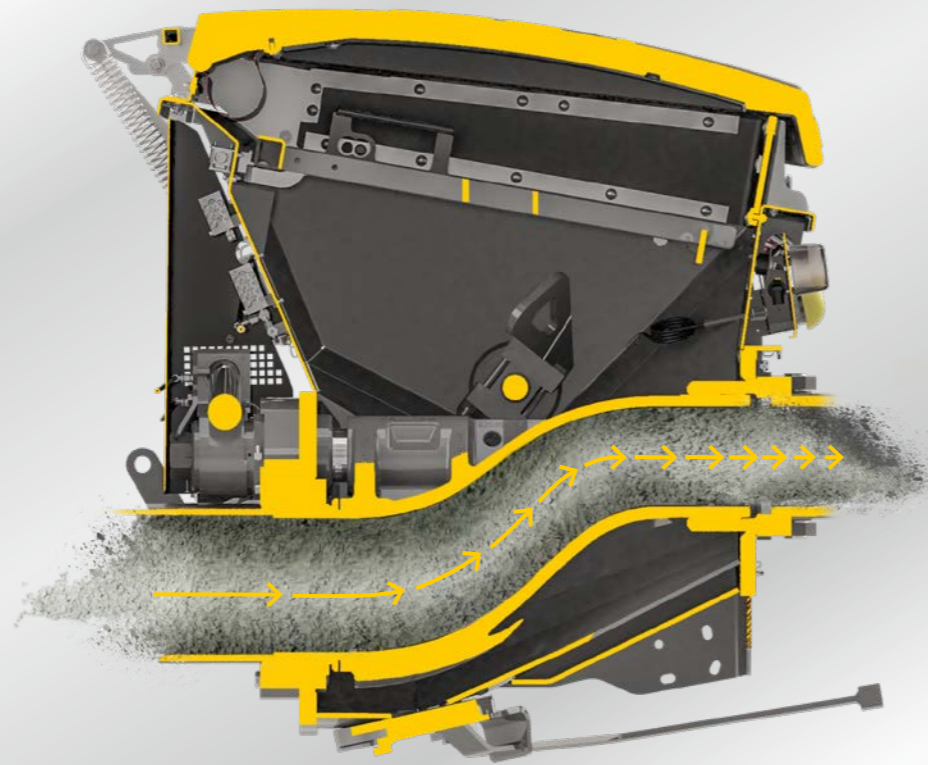

## Longlife pistons for long-lasting thrust

We can fit all iLS pumps with longlife pistons as an option. These high-quality pistons cut operating costs by 50 % compared to standard pistons. We call this efficient concrete conveying:

- Service life 2 to 3-times longer than standard pistons
- Especially suitable for high pressures and abrasive concretes
- Low wear costs and high machine availability

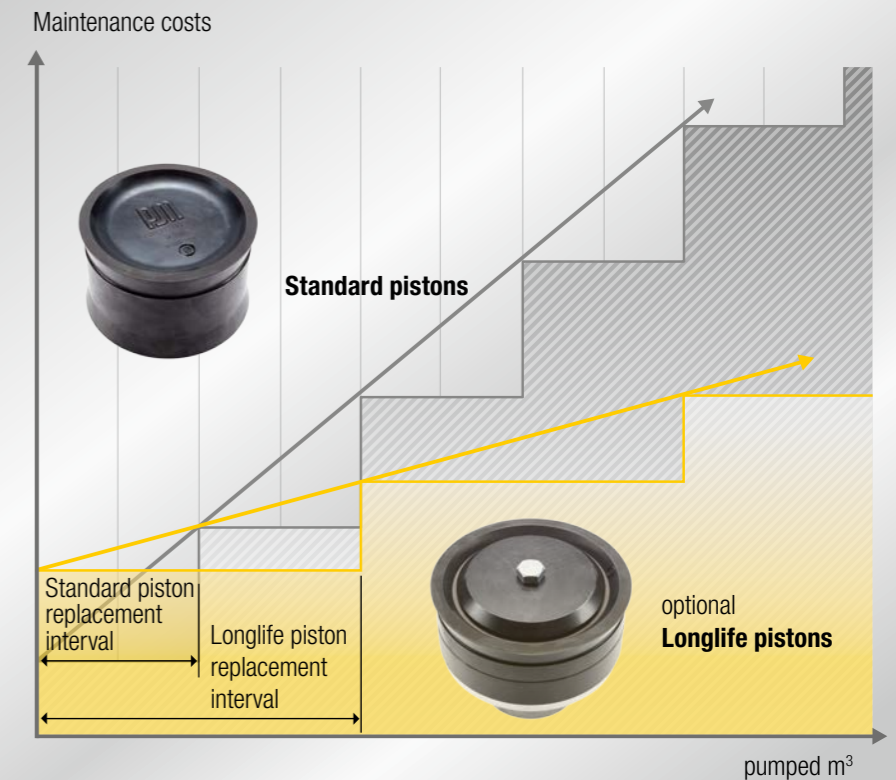

## Lubrication system

The shorter lubrication interval for all concrete bearings can minimise damage caused by the penetration of cement slurry. In addition, manual lubrication is possible with a grease gun at the distributor.

## Hydraulic pump control

The position of the conveying cylinder is continuously monitored and the stroke compensation mechanism automatically eliminates position deviations. The pump process is not interrupted and the pistons do not travel to the end positions to compensate the stroke.

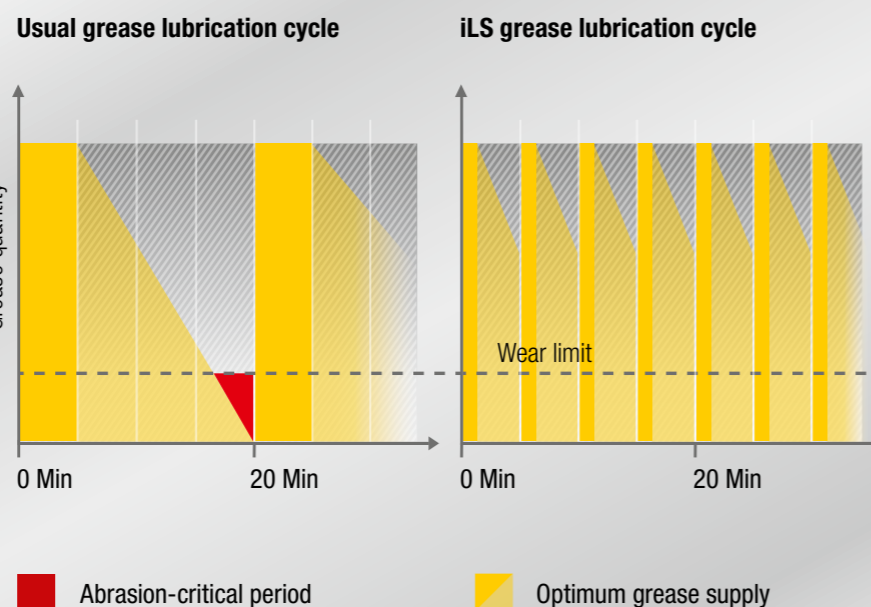

## Control centre for maximum efficiency

If our core pumps are the heart of the machine, Ergonic® is its head. As a control centre, the microprocessor-supported control systems regulate the functions of concrete pumps, truck mixers and PUMI®. Greater profitability, lower costs, more flexibility – this is the result when Putzmeister machines with Ergonic® manage the tough daily conditions on job sites. In combination with EOC, fuel savings of up to 25 % can be realistically achieved.



## Pumps: Select the power

Type	Output m³/h	Pressure bar	Stroke mm	Cylinder Ø mm	Strokes/min
15 iLS*	150	85	2 100	250	24
17 iLS	170	85	2 100	250	27
19 iLS	190	85	2 100	250	30

All data are theoretical maximum values.  
\* 15 iLS from the 30 m class only in combination with iONTRON

# The Putzmeister pump solutions at a glance

**Pump type**    **15 iLS / 17 iLS / 19 iLS**  
Operate extremely economically  
and meet extreme challenges!

## Special features

- Fuel savings of up to 25 %
- 3 % increased efficiency through the prevention of leaks
- 10 % better suction behaviour thanks to the elimination of constrictions in the concrete flow
- Optimised drive unit
- Maximum performance, minimum operating costs
- Optimised conveying unit – ideal for the the heaviest concretes
- Reduced wear for long service life
- Optimised accessibility for maintenance and service
- Automatic stroke correction without pump interruption
- Field-tested and robust
- Maximum quietness

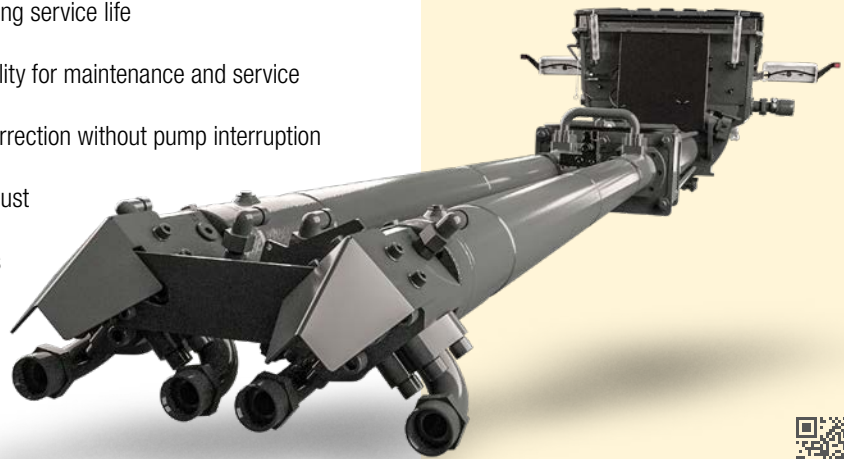

## Putzmeister Concrete Pumps GmbH

Max-Eyth-Straße 10 · 72631 Aichtal / Germany  
P.O.Box 2152 · 72629 Aichtal / Germany  
Tel. +49 (7127) 599-0 · Fax +49 (7127) 599-520  
pmw@putzmeister.com · www.putzmeister.com

