

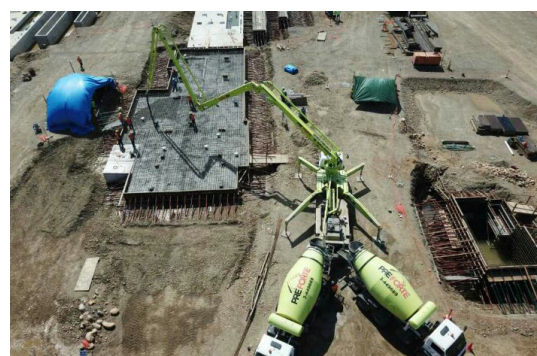

**Putzmeister**

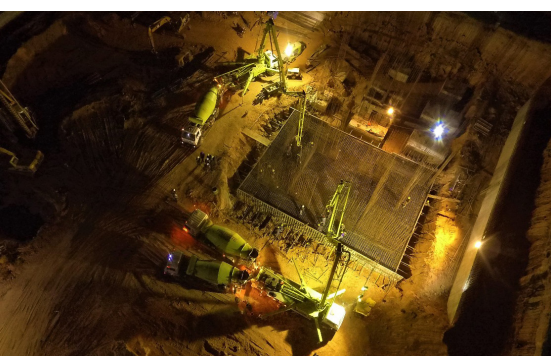

# 36Z Truck-Mounted Boom Pump

Technical specifications



# Versatile for all your jobsites

## Do more for less

The lightweight 36Z-Meter Concrete Boom Pump delivers greater payload capacity, longer pump life, and an improved design for increased ease of service. Each piece of the pump works together seamlessly while improving overall usability.

The 36Z weighs over 4,000 lbs less than the previous 36Z model. This allows for an increased payload capacity for job site equipment, water, and fuel. The 36Z has a three-axle chassis, allowing for less strict permits — even no permits — depending on local requirements.

With the relocation of several components, the deck has approximately 30% more space, allowing for ease of movement during maintenance and service, and provides an increase in physical space for the payload. The life of the pump has increased with the pedestal sub-frame's bolted connections, which allows for flexibility by adjusting to torsion from the force of the pump.



## Free flow hydraulics in a closed loop system

- Changes in material pressure in the delivery line are reduced to ensure smooth pumping and a consistent concrete flow.
- The intelligent design minimizes wear-inducing pressure peaks, increases service life, and makes our pumps extremely powerful.
- Rapid change-over of the stroke means higher outputs, a smoother flow of concrete, and less boom bounce.
- There is greater pump output due to the efficient use of all available energy.

## Other benefits at a glance

### Boom

- 4-section Z-fold design
- More flexibility in the boom eliminates dead space
- Compact structure with low unfolding height
- Fast control response characteristics
- Lubrication for first boom cylinder and slewing bearing
- Standard 90° and 45° elbows, with lengthened collars for a longer service life
- Reduced boom vibrations

### Pedestal

- Increased robustness and stability
- Low weight offers high payload capacity
- Space-saving TRDI support system
- Plenty of storage space on the deck
- One-sided support (OSS) outrigger system
- Economically advantageous with maintenance-free, standard, and bolt-on components

### Pump

- Engineered for all common concrete types
- Service-friendly control system with exclusive free flow hydraulics
- Wear-resistant design of S-Valve
- Optimized hopper with optimized shape
- Hopper agitator safety shutdown via Radio Frequency Identification (RFID)
- Automatic agitator direction of rotation corresponds to pumping direction
- Optimized pumping with EPS and EOC
- Optimized switchover procedure and Push-Over avoids wear-intensive pressure peaks

**Putzmeister**

**PRO-VANTAGE®**  
WARRANTY PLAN

The PRO-VANTAGE® Warranty Plan extends the coverage on all Putzmeister BSF boom pumps for a total of 36 months or 6,600 hours at no extra charge. Domestic only.

# The boom - uniquely flexible in any application

## A better boom design

The 36Z rectangle boom design minimizes boom bounce, and is easier to maneuver. The boom features more straight pipe for a less stressful concrete flow and longer wear on parts. The Z-Fold configuration handles space-restrictive areas and can pump even when the boom is not fully extended. Putzmeister's boom design is highly responsive and has been optimized for the greatest maneuverability and flexibility available, resulting in a larger operational range.



### Easy to operate

Even in tight spaces, the boom control ensures that you can work optimally. Minimized boom vibrations make placing easier; this saves valuable working time and guarantees a high level of safety.



### Bolt connections

Critical wear areas have been improved with bolt connections. The bolt connections provide extended service life and easier maintenance by simplifying the design and allowing for torsion forces to easily pass through.

## Standard features

### Concrete Pump Unit

- Free flow hydraulics
- Multi-piece piston cups
- S-Valve - 2318 hard-faced (9" to 7")
- RS 909 clean out hopper w/ solid polyurethane fold down back splash
- Hardox remixer paddles
- Hopper vibrator
- Hopper agitator safety shutdown via Radio Frequency Identification (RFID)
- Hard-chromed material cylinders
- Proximity switches w/ indicator
- Hydraulic outriggers - front & rear
- Snap-locks for outriggers & bubble level indicators
- 406 psi (28 bar) high pressure water pump
- 185 gal (700 L) composite water tank
- Manual grease system - boom
- Auto-lube grease system - hopper / pedestal
- Centralized lube locations
- Gauge Port Central (GPC)
- Loading decks for pipe & accessories
- Modular bolt-on flatpack
- Large side-mounted aluminum toolboxes
- Swing out step (left side)
- Operator Supervision Warning System (OSWS)
- 5" delivery line on boom & deck pipe
- Proline 3000 Putzmeister Pipe Technology (PPT) w/ 10 ft (3m) delivery hose w/ coupling
- Electric oil cooler
- Wash out kit & hose
- Light kit package at boom, pedestal, & hopper
- 4 outrigger pads w/ 2 side compartments
- Wireless & cable remote

### Unit Control System

- Ergonic 3.0 w/ Ergonic Output Control (EOC)
- Standard world pattern
- Radio remote w/ Ergonic Graphic Display Remote Control (EGD-RC) w/ full proportionality & 20m cable back-up option
- Ergonic Graphic Display in control cabinet
- Cable remote w/ full proportionality
- Remote on/off of concrete pump & remote engine off

### Miscellaneous

- Ship-away kit w/ basic maintenance tools
- Operational & safety manuals
- High quality paint finish



# The pedestal – robust and stable for optimum reliability

## TRDI Support

With TRDI support developed by Putzmeister, you can save time and space without compromising on safety. Telescoping outriggers can be placed between obstacles and in the smallest of spaces — a huge advantage when working under restrictive setup conditions.

### **Narrower support with optional One-Sided Support (OSS)**

With OSS, the outrigger footprint is reduced even further. This ensures that the boom's total reach on the fully supported side is optimally used.



## RS 909 Hopper

Putzmeister's robust, yet lightweight EZ Clean Out RS 909 hopper is engineered for performance and durability, and is ideal for high pressure applications and harsh mixes. Offering 19.4 ft<sup>3</sup> (550 L) capacity, the hopper uses one remixer paddle motor and grate-mounted vibrator. An innovative RFID safety switch in the hopper disables the machine when the grate is opened.

### **RS 909 Hopper features**

- Hinged splash guard
- Automatic lubrication
- Hopper work light
- Hard-faced S-Valve
- Gradual 9" to 7" (230mm to 180 mm) reduction
- Thick-walled valve construction
- Fast and easy clean out



## Other Available Options

Auto Lube System - Boom

High pressure washer (2000 psi / 138 bar)

Hopper step (right hand side) hinged

Oil tank heater

One-Sided Support (OSS) Outriggers

Outrigger aux fuel tank (DOT approved)

Outrigger lightbar

Outrigger saddle tank / fuel selector valve

Partial Flow Filter / Dehydrator

Squeeze valve air line installation

Squeeze valve installation w/ PM EQV part

Wash-out hose reel kit

Water tank heater



# iLS pump – highlights

## The Putzmeister iLS pump generation is setting standards across the board

The heart of every truck-mounted concrete pump is the pump itself. The iLS pump generation delivers significantly improved data across the board and is the logical advancement of the tried and proven HLS generation.

### Special features

- Fuel savings of up to 25%
- 3% increased efficiency with leak prevention
- 10% better suction resulting from the elimination of constrictions in the concrete flow
- Optimized drive unit
- Optimized conveying unit – ideal for the heaviest concretes
- Reduced wear for long service life
- Optimized accessibility for maintenance and service
- Automatic stroke correction without pump interruption
- Field-tested and robust
- Reduced noise

#### Hopper

The hopper has a user-friendly and low-maintenance ergonomic design. It is RFID protected, the grill is welded, and the hopper cover can be locked in 4 positions.

#### Lubrication system

The grease cycles have been adapted to better protect all concrete bearings from wear.

#### Concrete cylinder

Eliminating the constriction before the S transfer tube has resulted in calmer pump behavior and improved efficiency. On longer sections, the reduction from 250 mm to 180 mm occurs only in the S transfer tube.

#### Drive cylinder

Hydraulic circuits further relieved through automatic stroke compensation and the elimination of pressure peaks in the end bearings.

#### Seals

Designed for maximum reliability for outstanding system performance.

#### S transfer tube

The hardened valve operates smoothly and guarantees extreme durability.

#### S transfer tube swivel bearing

The hopper wall thickness and bearing surface have been doubled for maximum reliability.

**LONGER SERVICE LIFE**  
**LOW MAINTENANCE**  
**OPTIMIZED EFFICIENCY**  
**OPTIMIZED ACCESSIBILITY**  
**EASY CLEANING**  
**BEST PERFORMANCE!**

# Ergonic® 3 – highlights

## The new Ergonic® 3 – clear, fast, and safe

- **Continuous operating concept** for all Putzmeister products with the same functions and displays – whether on the radio remote control or the Ergonic Graphic Display (EGD).
- **Intuitive work and quick reactions** thanks to a clear menu structure and intuitively arranged functions.
- **Full overview** of machine status on the radio remote control and EGD (incl. valves, sensors, and LEDs on fuses).
- **Detailed fault management:** Faults are easy to detect and rectify – even without a Putzmeister technician.
- **Multi-level emergency operation** keeps the machine running even in the toughest conditions.

AS EASY TO OPERATE  
AND MORE INTUITIVE  
THAN EVER BEFORE

**ERGONIC® 3**



### Pumping made smart

If our concrete pumps are the heart of Putzmeister machines, then the Ergonic system is the brain.

As a switching center, the microprocessor-supported control systems regulate the functions of concrete pumps and placing booms.

### Always by your side – Ergonic® 3 inside

#### **EPS** Ergonic Pump System

Takes control of the concrete pump for optimized pumping.

#### **EOC** Ergonic Output Control

Regulates the optimum motor speed for smooth operation with fuel efficiency and low wear.



## Ready for the future

- **A future-oriented solution** with interfaces for future expansions and easy software updates.
- **Service-friendly concept** with services that can be accessed and implemented efficiently.
- **Clearly guided fault management** on the radio remote control and display.

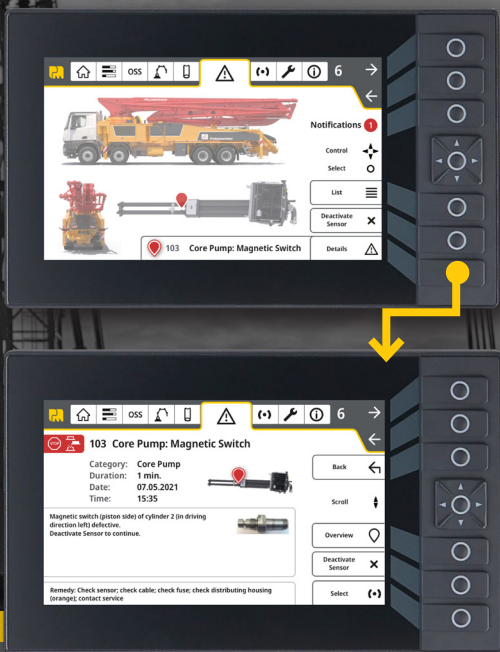

## The best of two worlds

Ergonic<sup>®</sup> 3 is the logical evolution of Ergonic<sup>®</sup> 1 and Ergonic<sup>®</sup> 2.

Proven features are maintained, others developed further, and new and future-oriented functions are integrated.

- Experienced Putzmeister customers quickly become familiar with operation, making the switch incredibly easy.
- New customers will need little training or instructions since operation is so intuitive.
- Once learned, a wide variety of machine models can be operated.

## Keeping an overview in every situation

- The static menu bar guides users through the available functions.
- Neatly and intuitively arranged functions.
- Simple menu structure with a maximum of two submenu levels.
- Main menu with all standard functions and additional details in submenus.

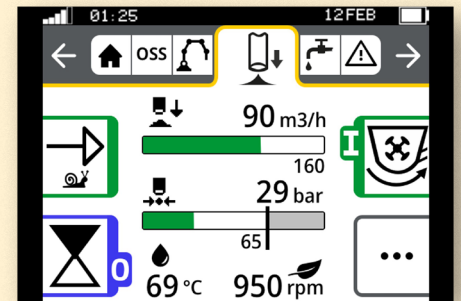

Main menu

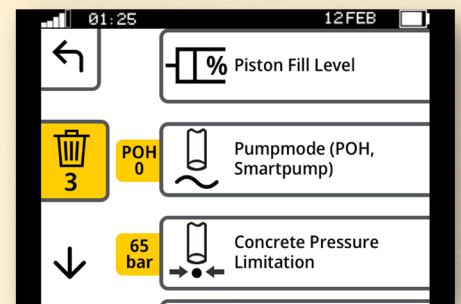

Submenu level 1

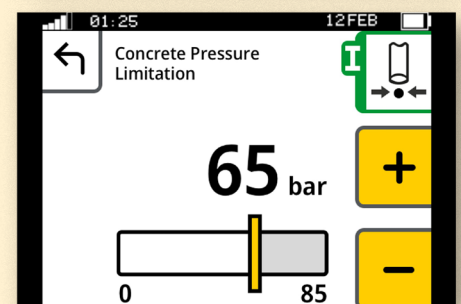

Submenu level 2

## SIMPLE OPERATION

Easy and intuitive, for all machine operators.

## RELIABLE OPERATION

With a comprehensive fault management.

## DETAILED FAULT MANAGEMENT

Comprehensive fault messages with suggested solutions.

# You can rely on Putzmeister – service, parts, and training

## Everything that sets service apart

Putzmeister provides first class service with swift assistance, meaningful advice, and a reliable supply of genuine Putzmeister parts and accessories in over 120 countries.

### Ideally placed to support you

We continuously train our service technicians, provide a close-knit information network, and the latest equipment to consistently strive to meet our customers' needs.

Our employees have all the relevant technical information about your machine at their fingertips, allowing us to provide you with the best possible support for emergencies, repairs, or preventive maintenance.



## Our services for cost-effective work

The Putzmeister service support points offer you these services - all provided by our experienced service staff:

### Customer training – benefit from expert knowledge

Practice-oriented learning offers many benefits: Master the machine and all of its special features, use the machine to optimum effect, reduce operating costs, and avoid operating errors.

### Mandatory machine inspection – calculable costs instead of incalculable failures

Visual inspection and functional check of components for 100% safety. The hydraulic system with cylinders, electrical system, and core pump are also inspected.

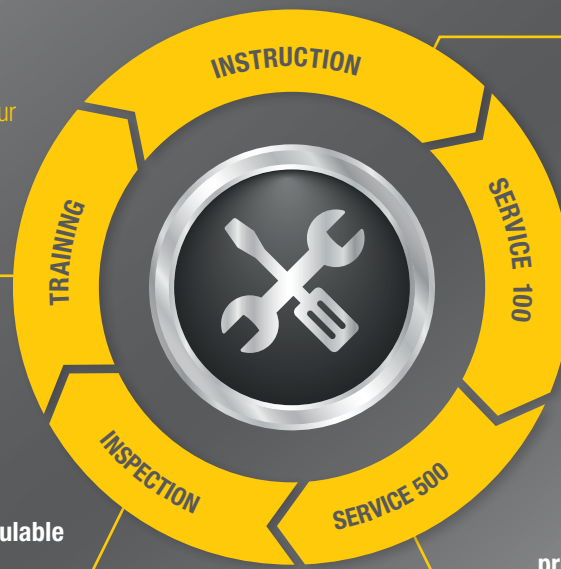

### Introduction at handover – everything correct from the get-go

You and your team can adapt perfectly to all features and innovations.

### 100 hours of customer service – avoid potential sources of error

Receive a status report on your concrete pump per the Putzmeister service plan.

### 500 hours of customer service – protect your investment, retain your value

Our technical customer service team is the number one choice for checking the safety and wear of your machine.





## Putzmeister Academy - Service Schools

We want to make sure you get the most from your Putzmeister equipment. To maximize the use and profitability of your investment, take advantage of the regular training seminars at our Wisconsin headquarters.

Service Schools cover maintenance, operation, and inspection of boom pumps, Teelbelts, and Thom-Katts. They include hands-on training, problem-solving exercises, hands-on presentations, and safety training.



## Genuine parts for maximum availability

We use only genuine Putzmeister parts in our workshops to guarantee consistent quality. You can be sure that your machine meets the tough requirements with maximum performance and availability.

- Immediate availability worldwide through our extensive dealer network
- Longest possible service life and maximum reliability
- Minimal maintenance and repair work thanks to high-quality materials and tested quality
- Quick and easy replacement with precise fitting and no variations in quality
- Safety for your customers, your personnel, and your investment

## Product and training information — whenever, wherever

We consistently provide the most up-to-date product and training information through our YouTube channel. From the comfort of your own home to on the jobsite, you have access to hundreds of videos that showcase the latest and greatest Putzmeister products, how-to videos, demonstrations, and much more.



# 36Z-Meter Truck-Mounted Specifications

## Machine Dimensions

	Imperial	Metric
Length	37' 8"	11.48 m
Width	8' 2"	2.50 m
Height	12' 10"	3.92 m
Wheelbase	223"	5,664 mm

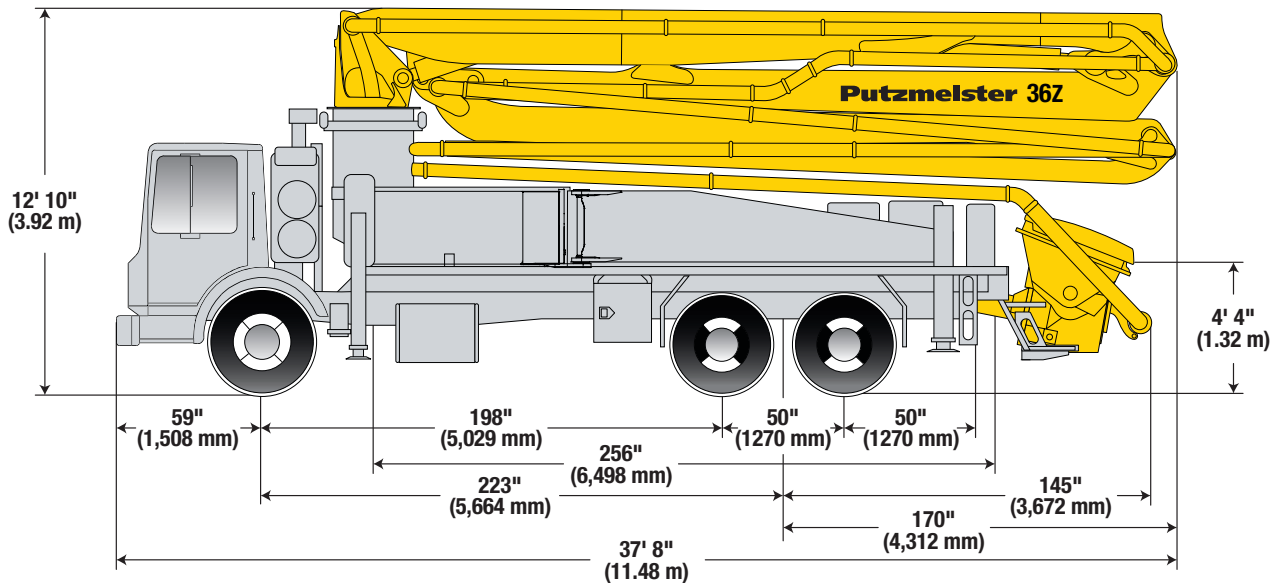

Based on Model BSF36-4.16H  
Mack 64R 6x4/223.

Dimensions will vary with different truck makes, models, and specifications.

Weights are approximate and include pump, boom, truck, driver, and full fuel tank. Varies with options selected.

Maximum theoretical pump values listed.

\* Applies to units mounted on a PMA stock truck - Mack 64R 6x4.

- Standard delivery line system rated at max line pressure of 1,233 psi (85 bar)

## Outrigger Spreads

	Imperial	Metric
Front — L - R   hydraulically extended out & down	18' 0"	5.50 m
Rear — L - R   hydraulically swing out & extend down	23' 1"	7.04 m

### Standard

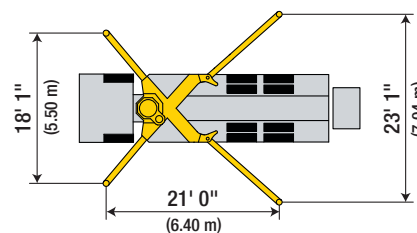

### One-Side Support (OSS)

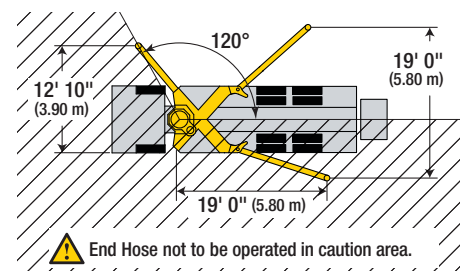

## Weight

	Imperial	Metric
Front axle weight	18,305 lbs	8,303 kg
Rear axle weight	34,467 lbs	15,638 kg
Approximate total weight	52,781 lbs	23,941 kg



### Boom

Z-folding Design	Imperial	Metric
<b>Height &amp; Reach</b>		
Vertical reach	117' 2"	35.70 m
Horizontal reach	103' 0"	31.40 m
Reach from front of truck*	94' 2"	28.70 m
Reach depth	76' 1"	23.20 m
Unfolding height	27' 7"	8.40 m

### 4-Section Boom

1 <sup>st</sup> section articulation	100°	
2 <sup>nd</sup> section articulation	180°	
3 <sup>rd</sup> section articulation	245°	
4 <sup>th</sup> section articulation	230°	
1 <sup>st</sup> section length	29' 2"	8.90 m
2 <sup>nd</sup> section length	24' 3"	7.40 m
3 <sup>rd</sup> section length	24' 7"	7.50 m
4 <sup>th</sup> section length	25' 11"	7.90 m

### General Specifications

	Imperial	Metric
Pipeline Size (ID) metric ends	5"	125 mm
Rotation	365°	
End hose — length	10' 0"	3.00 m
End hose — diameter	5"	125 mm

### Range Diagram

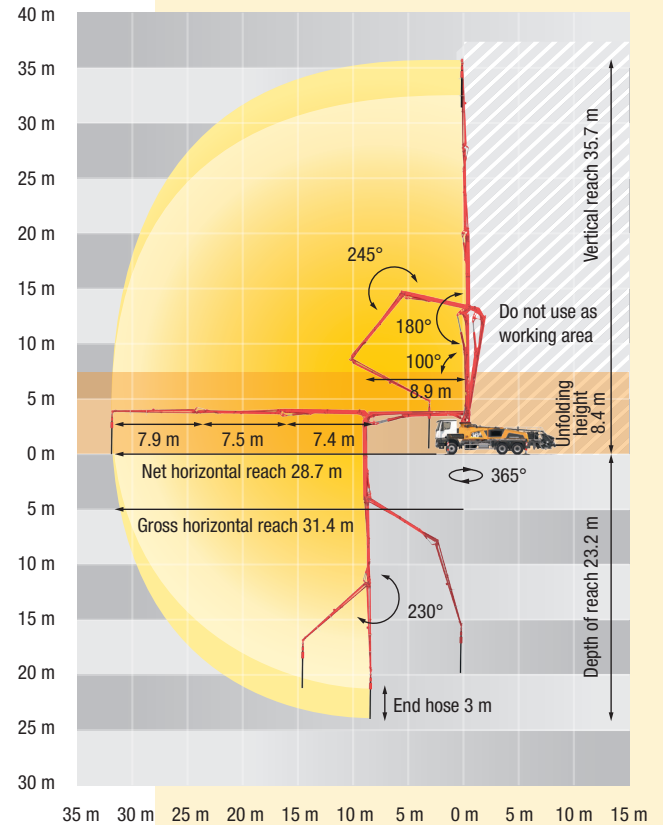

Pump		36Z.16 H		36Z.17 ILS	
		Imperial	Metric	Imperial	Metric
Output	Rod side	209 yd <sup>3</sup> /hr	160 m <sup>3</sup> /hr	—	—
	Piston side	141 yd <sup>3</sup> /hr	108 m <sup>3</sup> /hr	222 yd <sup>3</sup> /hr	170 m <sup>3</sup> /hr
Pressure	Rod side	1,233 psi	85 bar	—	—
	Piston side	1,885 psi •	130 bar •	1,233 psi	85 bar
Material cylinder diameter		9"	230 mm	10"	250 mm
Stroke length		83"	2,100 mm	83"	2,100 mm
Maximum strokes per minute	Rod side		31		—
	Piston side		21		28
Volume control			0-Full		0-Full
Vibrator			Standard		Standard
Hard-chromed material cylinders			Standard		Standard
Hydraulic system			Free Flow		Free Flow
Hydraulic system pressure		5,075 psi	350 bar	6,092 psi	420 bar
Differential cylinder diameter		5.5"	140 mm	4.5"	115 mm
Rod diameter		3.1"	80 mm	3.1"	80 mm
Maximum size aggregate		2.5"	63 mm	2.5"	63 mm
Water tank — pedestal		185 gal	700 L	185 gal	700 L

# Here for you every step of the way

## Our Putzmeister Promise

We build machines that increase your production and give you a competitive edge – and these machines are continuously developed. Innovative technologies and durable quality need to adapt to your ever-changing daily challenges. Our products stand for optimum output with low fuel consumption, wear, and costs.

Our customers will always have a thinking, intelligent partner in all their undertakings; a partner that will deliver to their exact requirements regardless of the complexity of the task or the remoteness of the scale. With knowledge and understanding backed by experience, we approach every task with renewed enthusiasm – be it a small scale construction or a mass assignment, tight deadlines, or unique concreting and manufacturing needs.

## Your Putzmeister Team



Authorized Distributor © Putzmeister America, Inc. 2024. CT 4427-3 EN.  
Photos and drawings are for illustrative purposes only and may not depict the final model.



# Putzmeister

Putzmeister America, Inc.  
1733 90th Street  
Sturtevant, WI 53177 USA  
[Putzmeister.com](http://Putzmeister.com)

Phone (262) 886-3200  
Toll-free (800) 884-7210  
Fax (262) 884-6338  
[pmr@putzmeister.com](mailto:pmr@putzmeister.com)