



Putzmeister



SPM 715 SYNCHRO AND SPM 718 SYNCHRO

Piston pump with synchronized additive dosing system.

Ideal for hand-held concrete spraying work or in combination with Wetkret 3 in tunnelling and mining

The piston pump for concrete spraying SPM 715 Synchro and SPM 718 Synchro, equipped with a hydraulic additive dosing unit which synchronizes the additive dosage with the concrete flow, is ideal for hand-held concrete spraying work.

The equipment combines the most powerful, large-scale pump technology with an extremely compact and user-friendly design. SPM 715 Synchro can reliably convey pumpable media with a grain size of up to 16 mm and SPM 718 Synchro up to 32 mm.

Both are available as a stationary or trailer pump to fit the requirements of all construction sites. With its road-going chassis, transportation and on-site manoeuvring could not be easier.



Versions:

Diesel engine Trailer pump

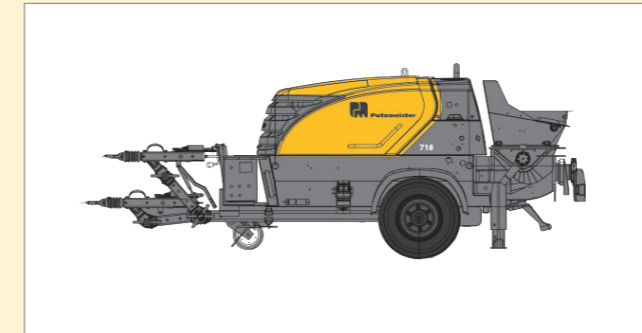

SPM 715/718 Synchro^{TD}

Diesel engine Stationary pump

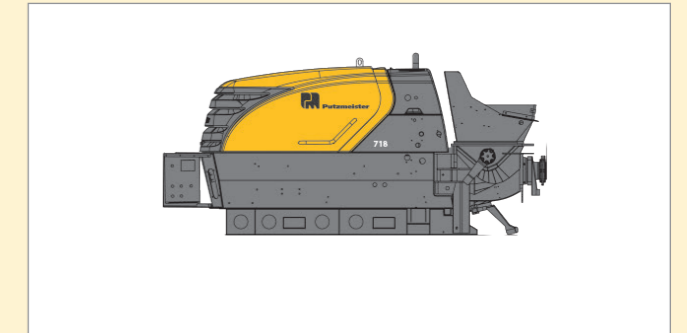

SPM 715/718 Synchro^{SD}

The perfect combination for robotic concrete spraying in tunnels with difficult access: Wetkret 3

If you prefer to perform a robotic application, Wetkret 3 is the perfect equipment. You can easily and quickly connect SPM 715 Synchro and SPM 718 Synchro pumps.

Wetkret 3 has been designed to work easily and safely in small tunnel sections with difficult access. Mounted on a compact crawler chassis, its telescopic spraying arm has a maximum reach of 8.79 m and is operated by remote control.

Wetkret 3 can be easily and quickly connected to the SPM 715 Synchro and SPM 718 Synchro pumps, air and additive supply, in a way that prevents the use of external hoses interfering with the work, to focus on the important, a perfect finish.



SPM 718 SYNCHRO

SPM 715 SYNCHRO



SPM 715

SYNCHRO

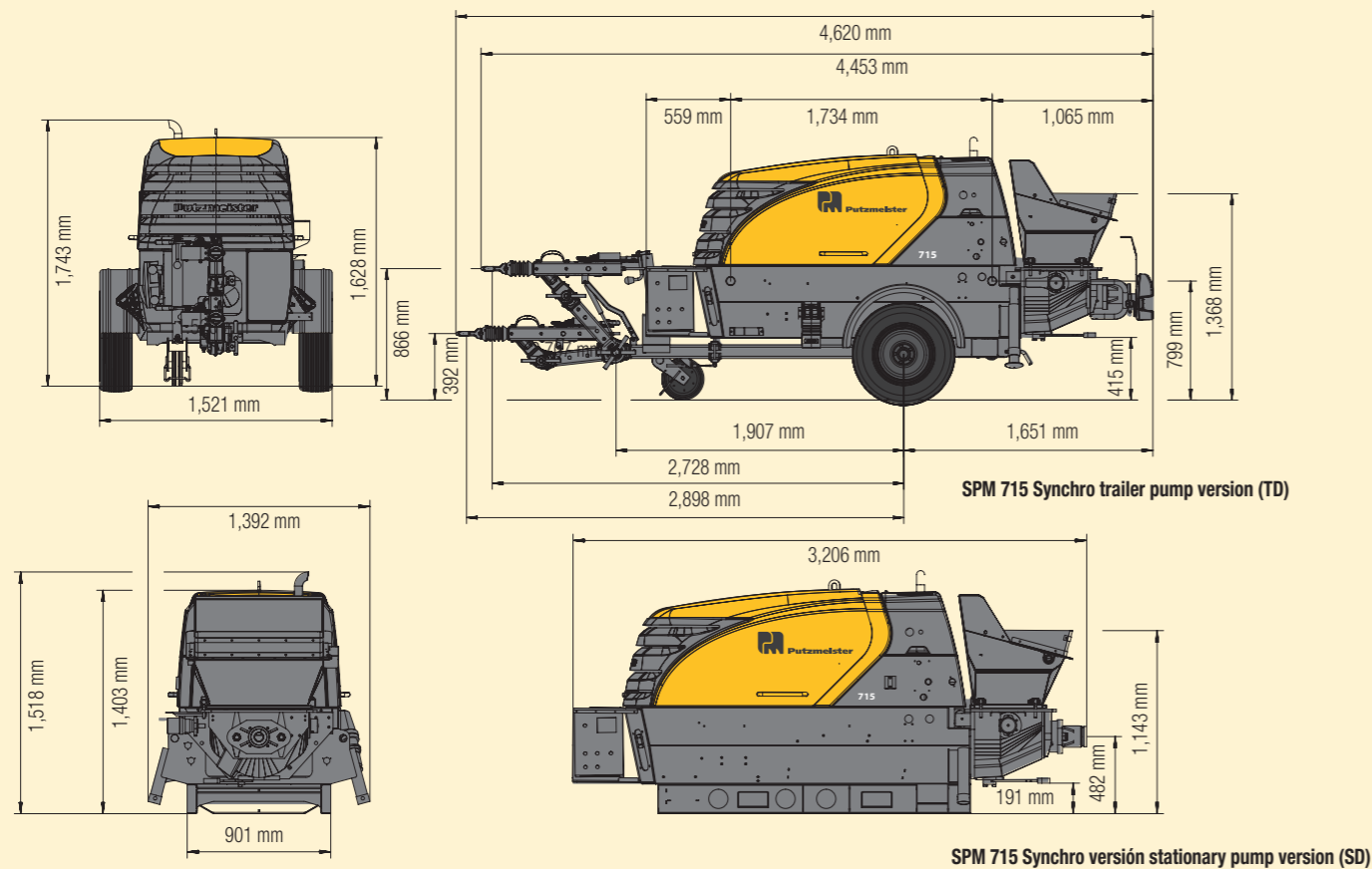

SPM 718

SYNCHRO

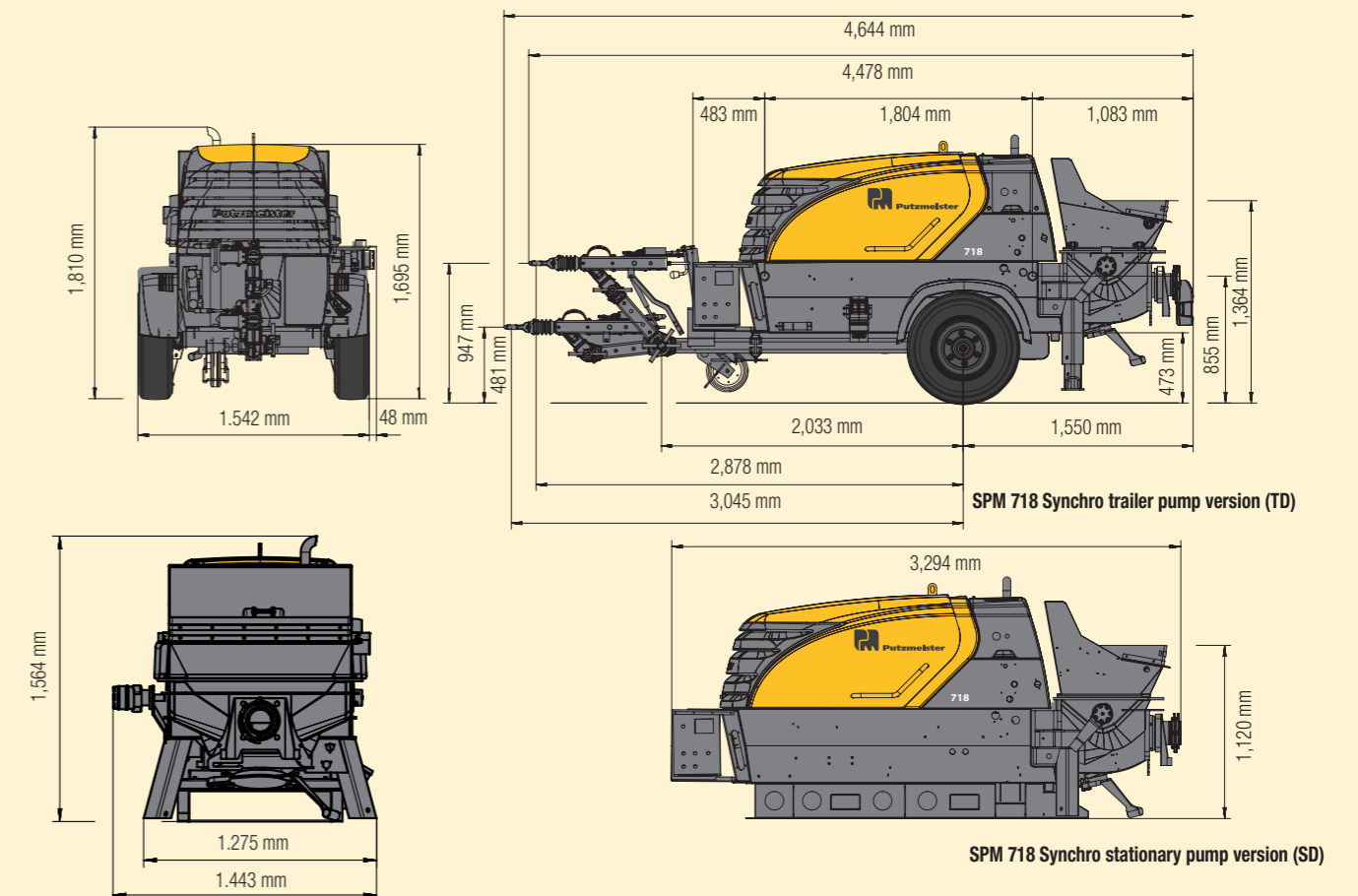

General data

Version	Trailer pump (TD)
Chassis	With brakes
Weight SPM 715 Synchro	Aprox. 1,850 kg
Weight SPM 718 Synchro	Aprox. 2,320 kg
Dimensions SPM 715 Synchro (Length x Width x Height)	4,568 x 1,520 x 1,749 mm
Dimensions SPM 718 Synchro (Length x Width x Height)	4,658 x 1,560 x 1,807 mm
Hoppe Filling height SPM 715 Synchro	1,368 mm
Hoppe Filling height SPM 718 Synchro	1,364 mm

General data

Version	Stationary pump (SD)
Chassis	Skid frame
Weight SPM 715 Synchro	Aprox. 1,700 kg (SD)
Weight SPM 718 Synchro	Aprox. 2,000 kg (SD)
Dimensions SPM 715 Synchro (Length x Width x Height)	2,939 x 1,392 x 1,518 mm
Dimensions SPM 718 Synchro (Length x Width x Height)	3,025 x 1,456 x 1,459 mm
Hoppe Filling height SPM 715 Synchro	1,143 mm
Hoppe Filling height SPM 718 Synchro	1,118 mm

Concrete pump

Diesel engine (TD, SD)	
Drive	Diesel engine
Power	Deutz D032011, 34.5 kW (3 cylinders)
Pump	Double piston, hydraulically driven
Theor. Concrete Flow	4 - 17.4 m³/h
Concrete pressure	68 bar
Cylinder diameter / piston stroke	150 mm / 700 mm
Strokes per minute	27/min
Maximum particle size SPM 715 Synchro	16 mm
Maximum particle size SPM 718 Synchro	32 mm
Hopper	TS 323 – Agitator in hopper and grill with electric vibrator. Steel or polymer fibre pumping
Concrete pipe	250 l / 280 l with rubber collar

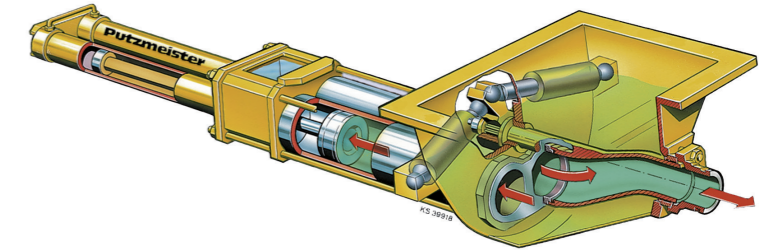

Synchronized additive dosing system

The adjustment of the additive dosage to the requirements of the construction site is an easy and reliable process with SPM 715 SYNCHRO. Just set the required values, and the system does the rest. The permanent control by the PLC over the system permits the automatic regulation of the liquid additive dosage in proportion to the concrete flow.

The hydraulically operated peristaltic additive pump provides a wide working range from 40 to 400 l/h, and the pumping values can be immediately checked on the PLC's display. That way, SPM 715 SYNCHRO guarantees high precision and quality concrete spraying.

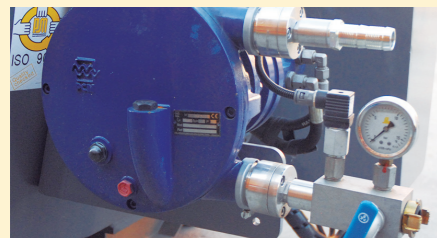

Synchronization of the additive dosage to the concrete flow through the PLC control panel and the hydraulic-operated peristaltic additive pump (40-400 l/h).



The reliable, oil-cooled 3-cylinder Deutz diesel engine complies with emission regulation Stage 3A



High tech concrete pumping: SPM 715 Synchro can reliably convey pumpable media with a grain size of up to 16 mm and SPM 718 Synchro up to 32 mm.



Maintenance and service-friendly: everything is protected below the canopy.



Compact and user-friendly design, it is available as a stationary or trailer chassis to fit the requirements of all construction sites.

Putzmeister synchronized additive pump

Type	Peristaltic pump, hydraulically operated
Synchronization	With automatic dosing device, proportional to concrete flow
Control system	Closed loop regulation and controlled by PLC
Adjustment range	40 - 400 l/h
Max. Working pressure	10 bar

Optional Equipment

Equipment for manual concrete spraying
Centralized lubrication system
Radio remote control
High pressure cleaner

Putzmeister Underground Technology

Visit our blog

Bestsupportunderground.com

Shotcrete in underground mining
and much more ...

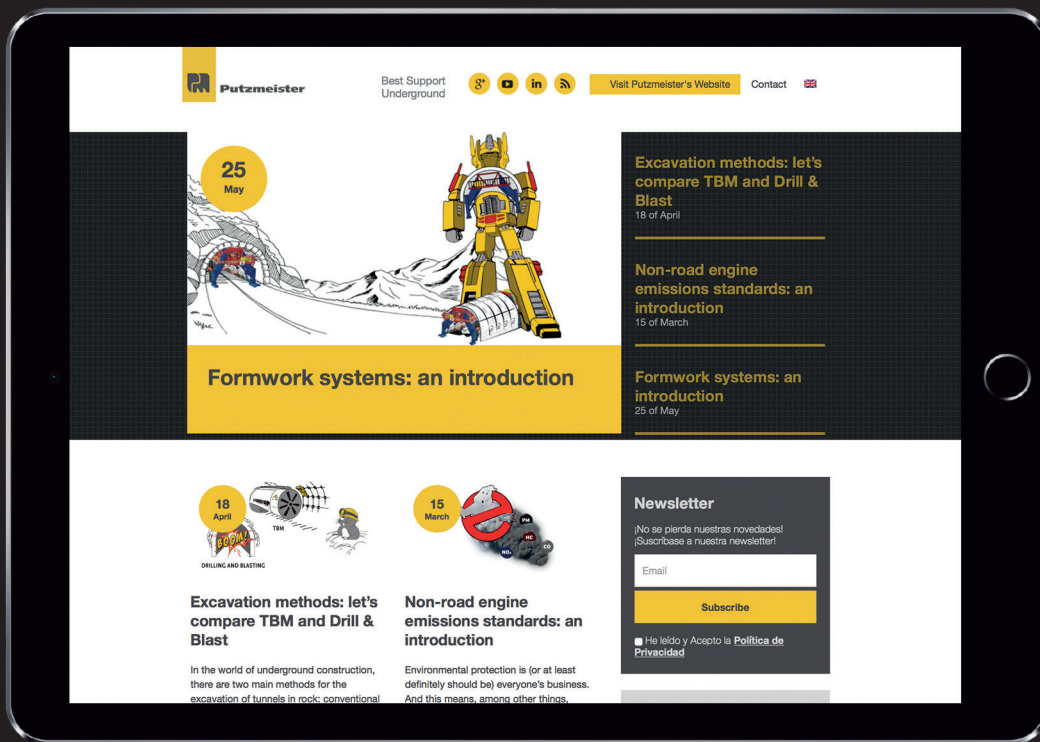

This is a merely informative, non-binding document. Maximum theoretical values listed. Specifications are subject to change without prior notice. Photos and drawings are for illustrative purposes only. For available options, please consult the factory.

Subject to technical modifications and errors · © Putzmeister Ibérica S.A. 2021 · All rights reserved · Printed in Spain · UT 4778 - 3 EN.

Distributed by

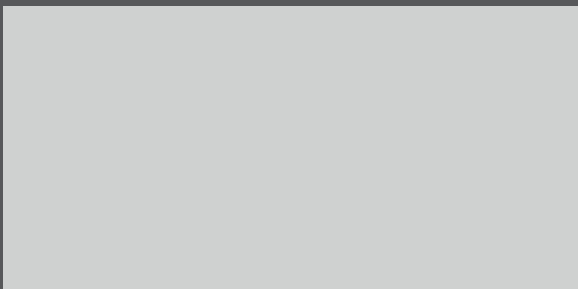

Putzmeister Ibérica S.A.

Camino de Hormigueras 173 · 28031, Madrid (España)

Tel. +34 91 428 8100 · contacto@putzmeister.com

www.putzmeisterunderground.com