

Rotary distributor

RV 16

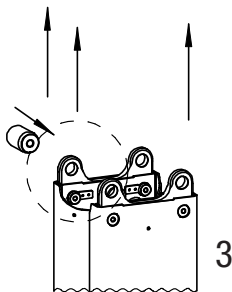
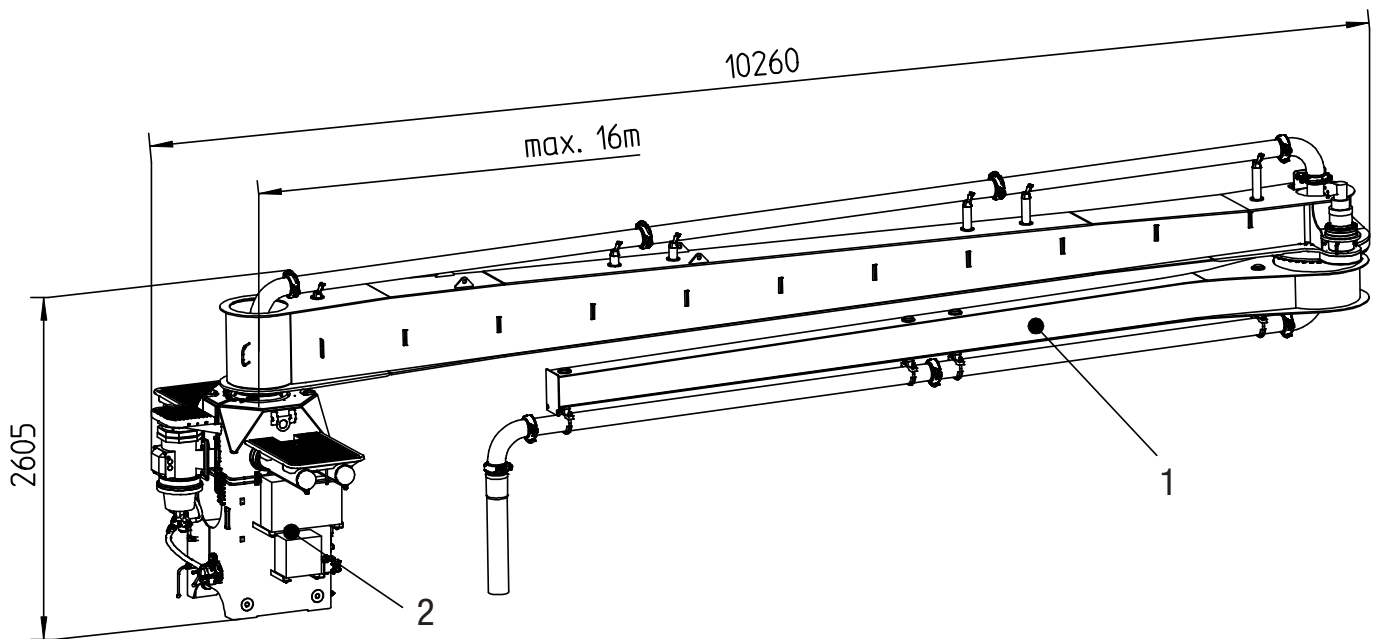

Description

- 1 2-section rotary distributor with concrete line and end hose
- 2 Boom pedestal with mounted hydraulic unit, integrated hydraulic oil tank and electric control cabinet
- 3 Putzmeister column system RS 850
- 4 Cross section Putzmeister column system RS 850 with suitable cut-out in the ceiling

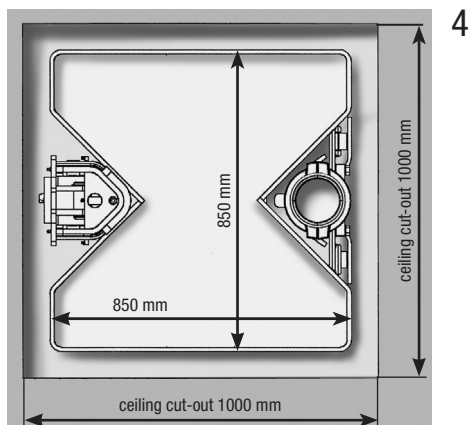

Note: Standard version. Dimensions and weights depend on equipment.

Reach information diagram

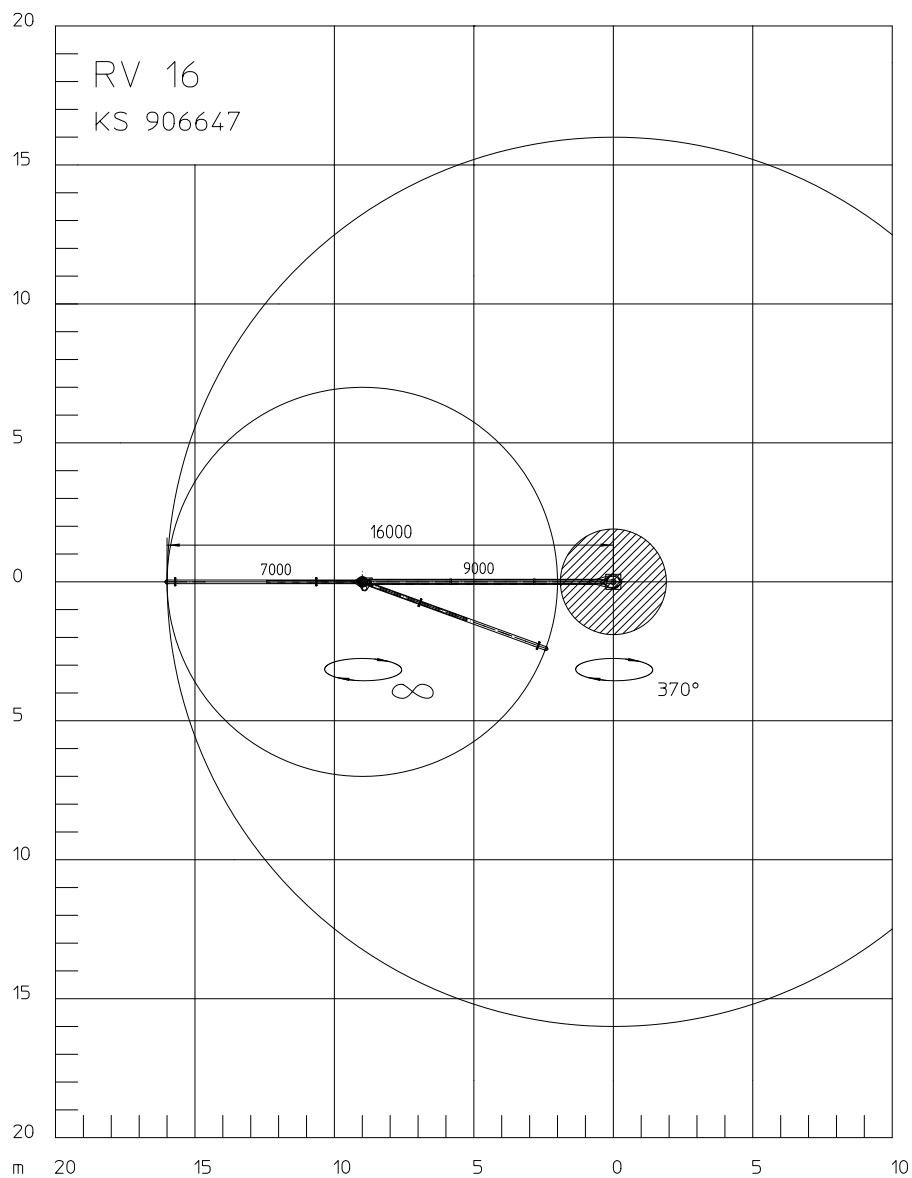

Technical data

| Stationary placing boom RV 16 | | |
|-------------------------------|---|--------|
| Sections | | 2 |
| Horizontal reach | m | 16 |
| Delivery line | | DN 125 |
| End hose length | m | 3 |
| Max. height w/o counterweight | m | 25.5 |
| Slewing range | ° | 370 |
| Weight (boom + pedestal) | t | 5.4 |

All data max. theor.

Dimensions can differ depending on configuration.

Serial delivery scope available on request