

# Stationary Placing Boom

MX 35-4

## The Key Benefits at a Glance

- 4-Section arm assembly with concrete line and end hose
- Boom pedestal with quick-seperating device, mounted hydraulic unit integrated hydraulic oil tank and eletrical control cabinet
- Putzmeister column system RS 751
- Cross section Putzmeister column system RS 751 with suitable cut-out in ceiling.

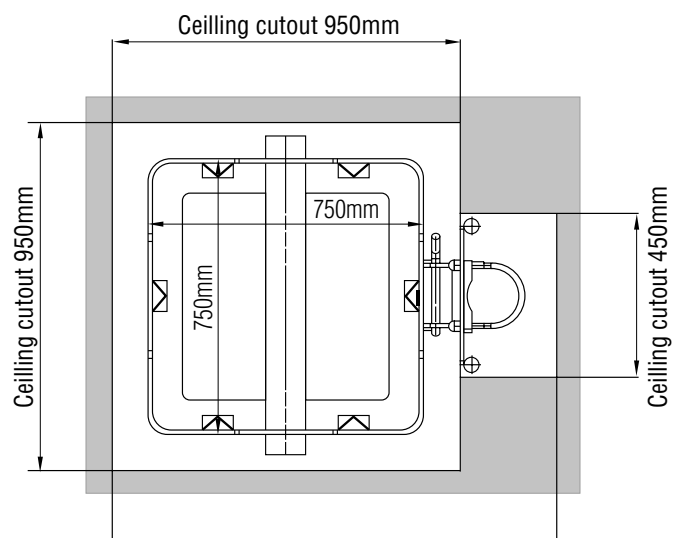

Note: Standard version. Dimensions and weights depend on equipment

## Reach Diagram

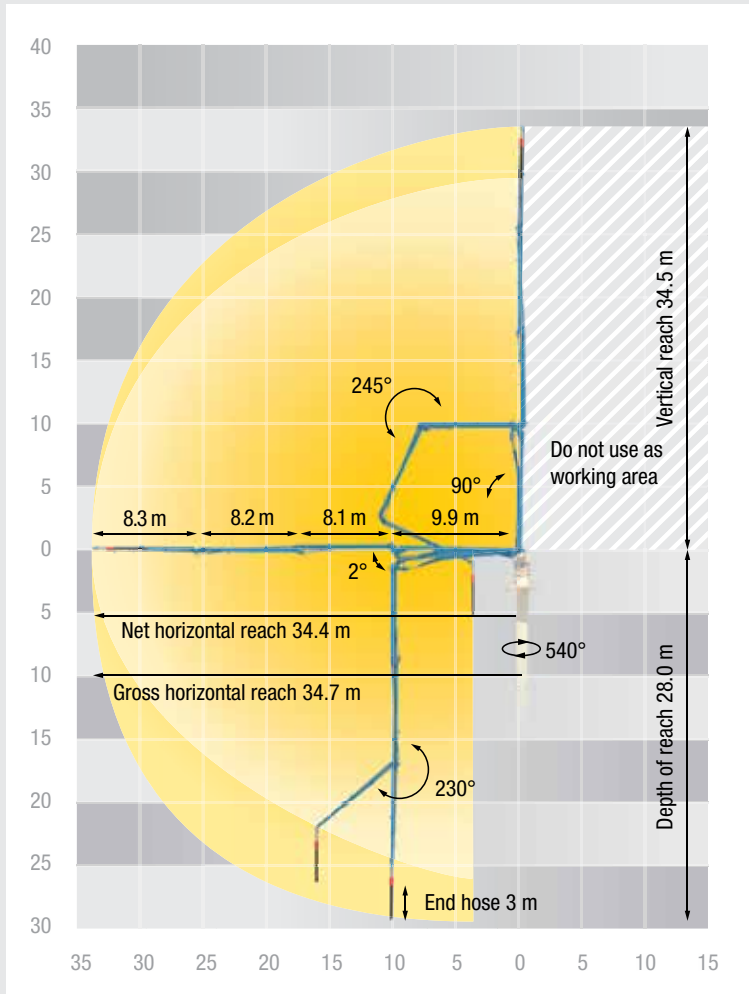

All data maximum theoretical  
Dimensions can differ depending on configuration

## Technical Data

### Stationary placing boom MX 35-4

Sections		4
Reach height	m	34.5
Horizontal reach:	m	34.7*
Reach depth max.	m	28.0
Delivery line		DN 125
End hose length	m	3
Max. height with counterweight	m	20
Free standing height	m	14
Slewing range	°	360
Weight	Boom	t 5.6
	Pedestal	t 2.5
	Ballast	t 4.2

## Serial delivery scope

Arm assembly MXR 3504 includes transport frame

Boom pedestal RS 751 includes transport frame

Delivery line DN 125 (1-layer)

End hose 3,0 m DN 125 5.5"

Operating manuals (1 x paper, 1 x CD-ROM) Spare part list

Painting: Arm assembly BLUE RAL 5012

Painting: Base structure RAL 1015 Light Ivory

Remote control with 40m cable

Working platform includes ladder

- SEE QUOTATION FOR EXACT SERIAL DELIVERY SCOPE.
- COMPREHENSIVE RANGE OF OPTIONS AVAILABLE ON REQUEST

### Putzmeister Concrete Machines Pvt. Ltd.

Plot No. N4, Phase 4, Verna Industrial Estate,  
Salcette - Goa 403 722. INDIA

Tel.: +91 (832) 6696 000 · Fax: +91 (832) 6696 300

Whatsapp: +91 91585 34123 · www.putzmeister.com



For all your support needs, [contact.india@putzmeister.com](mailto:contact.india@putzmeister.com)

# 1800 - 267 - 2678

TOLL-FREE NUMBER FOR ENQUIRIES AND SERVICE REQUESTS